

Custom Skylights

Our custom skylights can be designed to any size and configuration and to any security level, from burglarproof to bullet resistant. The size is only limited by your structural reality.

A steel sub-structure is carrying the aluminum surface structure with the double pane glass. The drawings on page 2 and 3 show technical details for the square skylight below:

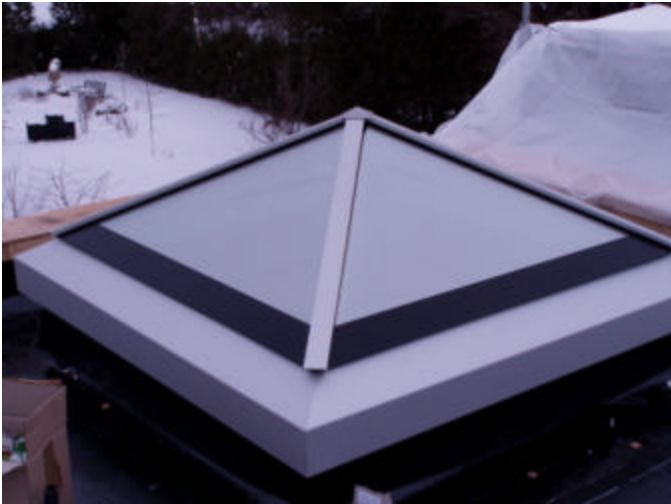

This same system offers superior insulation values and can be engineered to cover the length of your rooftop! This roof, still under construction, has a similar skylight that's 40 feet long (see below), and has all glass to a B1 security level. This works both for security and superior insulation value. Look for pictures of the finished project on our website (www.SwissShade.com) shortly.

Besides the high security values of the B 1 glazing, it also provides a sound insulation value of 52 dB and a 99% protection from harmful UV rays.

18 mm laminated glass – 12 mm Argon filled
Insulation space – 6mm tempered



40 foot skylight in B1 level security glass - superior insulation and protection

Stückliste			
BAUTEILNUMMER	Stck	TITEL	länge
210-201 Zarge	4	Bl.499/3-1540	
210-301 Pro-St	4	RR 80/60/3-	1000,5 mm
210-302 Pro-St	4	Bl.48/2-1006	
210-303 MBJ	4	Nr.2000	1233,7 mm
210-304 MBJ	4	Nr.1000	1267,3 mm
210-401 Ble-AL	4	Bl.433/3-1972	
210-402 MBJ-Deck	4	Nr.3200 + 3301	1215,5 mm
210-502 Glas	4		
210-601 Haube	1	Bl.xx/2-	

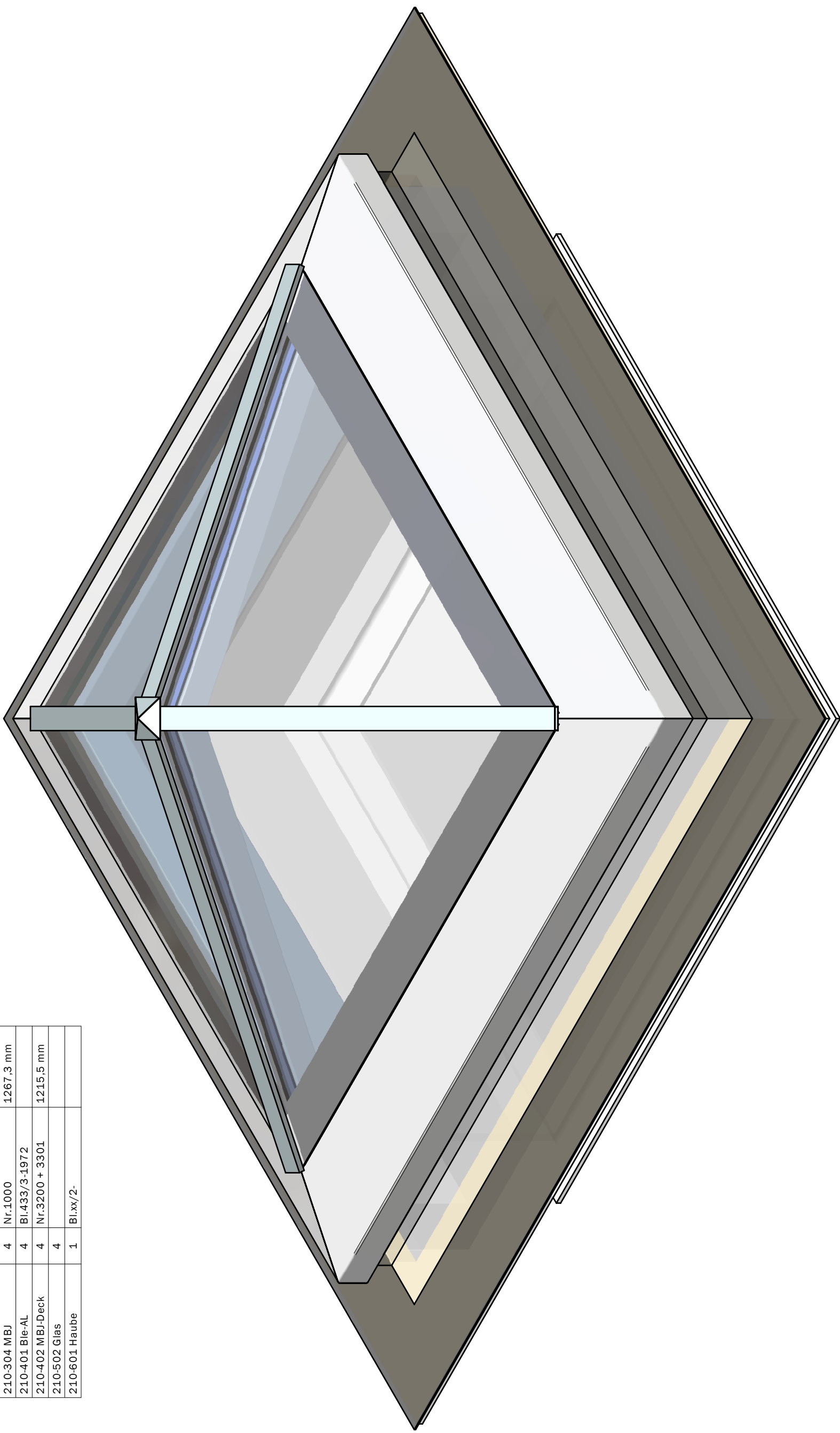

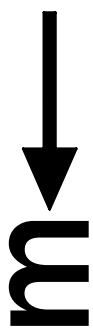

Karl Mutschler
Planungsbüro für den
Metallbau
07453 Telefon 6507
07453 Telefax 6520
www.metallobauplan.de
info@metallobauplan.de

C (1 : 2)

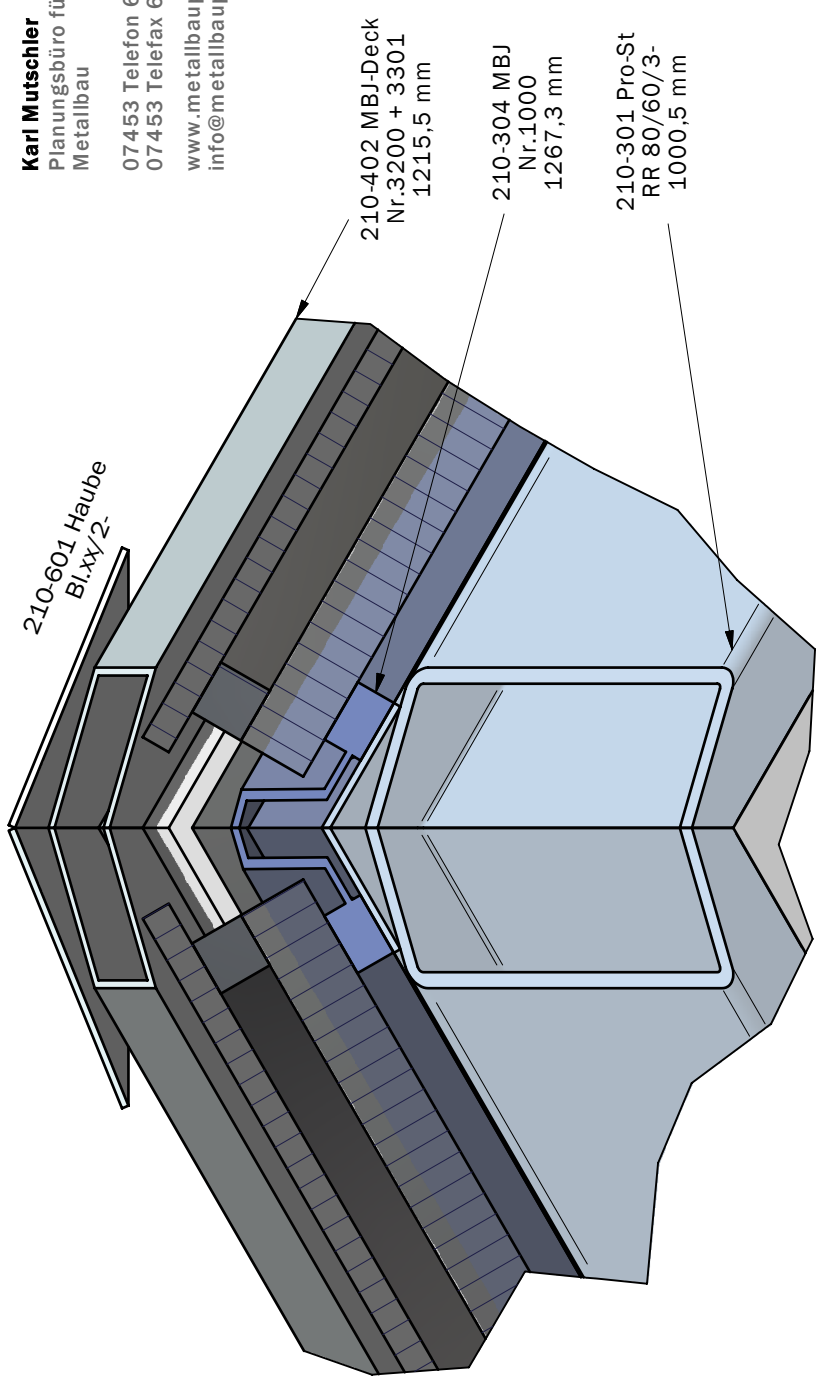

A-A (1 : 10)

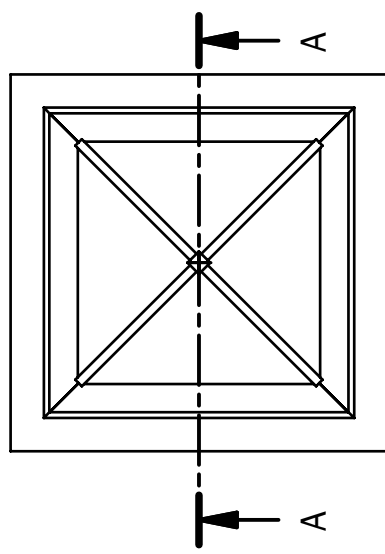
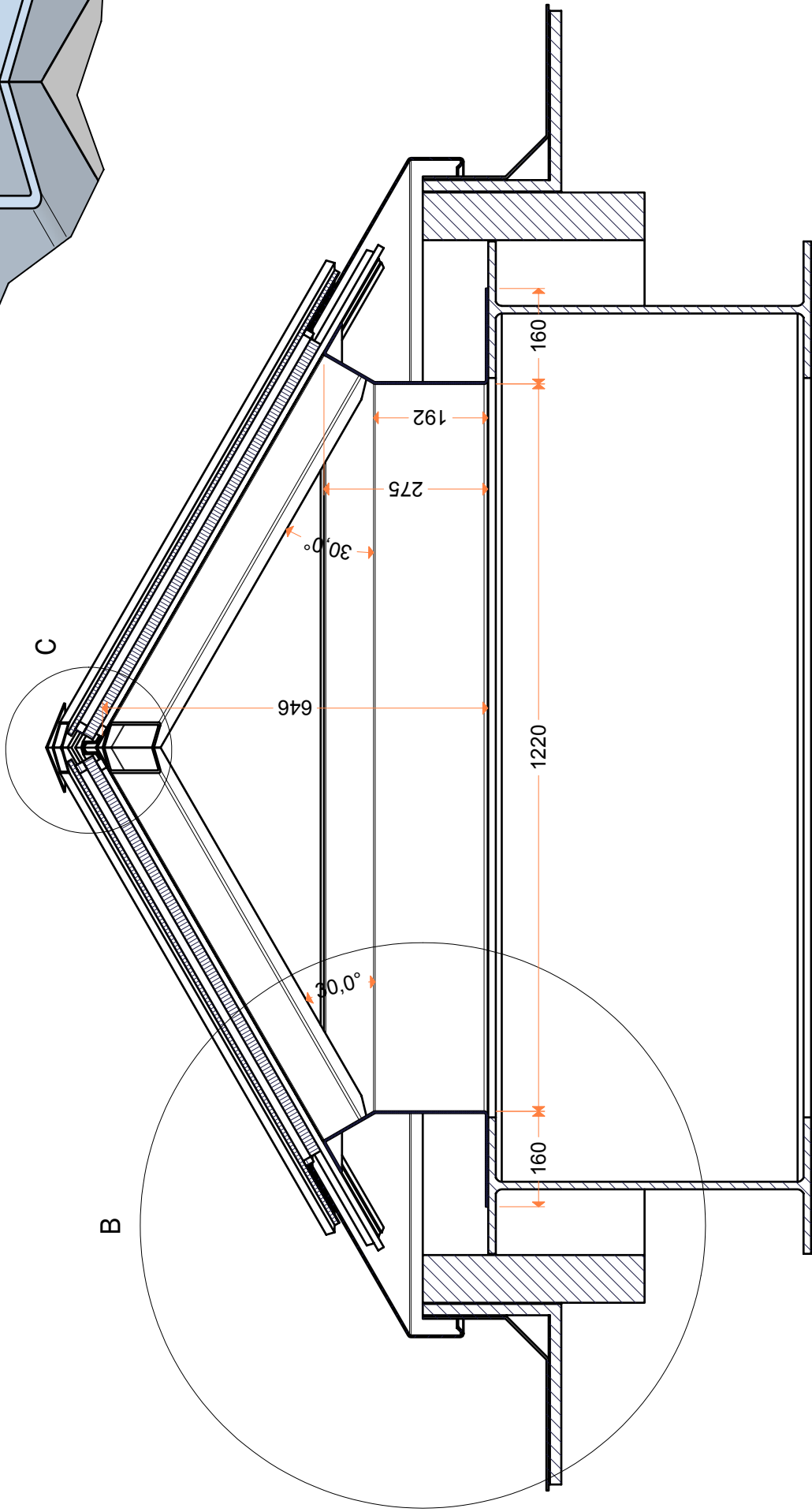

m ←

Karl Mutschler
Planungsbüro für den
Metallbau
07453 Telefon 6507
07453 Telefax 6520
www.metallobauplan.de
info@metallobauplan.de

B (1 : 2)

210-402 MBJ-Deck
Nr.3200 + 3301
1215,5 mm

210-304 MBJ
Nr.1000
1267,3 mm

326

3

09

101

210-301 Pro-St
RR 80/60/3-
1000,5 mm

150,0°

Hohlraum isoliert

189

210-201 Zarge
Bl.499/3-1540

160

3

3

88

-BV Oberlicht Kanada

Bauteil Übersicht Lichtkuppel

LV Pos. xx

Blatt-Nr. 203